

PHYSICS NYB

John Abbott College

SAMPLE FINAL EXAMINATION
Electricity & Magnetism

DURATION: 3 Hours

Instructors: C. Coulomb, A. Volta, A.M. Ampere, M. Faraday, G.R. Kirchoff

N.B. This sample final is meant to illustrate the type of question and level of difficulty to expect on a final exam in NYB. In no way is it meant to act as a comprehensive review or summary of the course material.

*See Physics Department Website for the equation
sheet that you can expect on your final exam*

PART 1: MULTIPLE CHOICE (20 marks)

1. Experimental evidence indicates that
- A) charge is quantized and conserved.
 - B) charge is quantized but not conserved.
 - C) charge is conserved but not quantized.
 - D) charge is neither quantized nor conserved.
 - E) None of these answers is correct.

2.

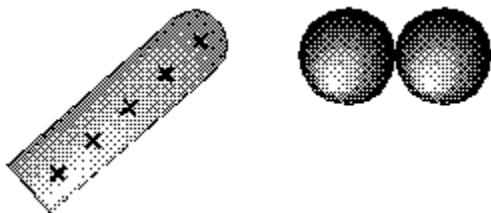

If you bring a positively charged insulator near two uncharged metallic spheres that are in contact and then separate the spheres, the sphere on the right will have

- A) no net charge.
- B) a positive charge.
- C) a negative charge.
- D) either a positive or negative charge.
- E) None of these is correct.

3.

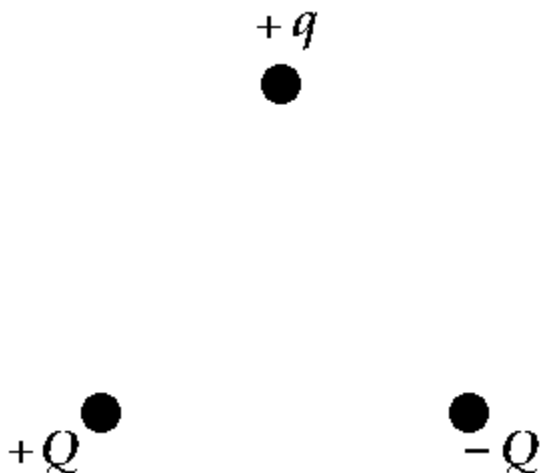

Three charges $+q$, $+Q$, and $-Q$ are placed at the corners of an equilateral triangle as shown. The net force on charge $+q$ due to the other two charges is

- A) vertically up.
 - B) vertically down.
 - C) zero.
 - D) horizontal to the left.
 - E) horizontal to the right.
4. Two charges of the same magnitude and sign are placed a certain distance apart. There is only one point in space near them where the electric field is zero. Which, if any, of the following statements about that point is true?
- A) It cannot be on the line joining the charges.
 - B) It must be on the line joining the charges and between the charges.
 - C) It must be on the line joining the charges but not between the charges.
 - D) Its position depends on the size of the charges.
 - E) None of these is correct.

5.

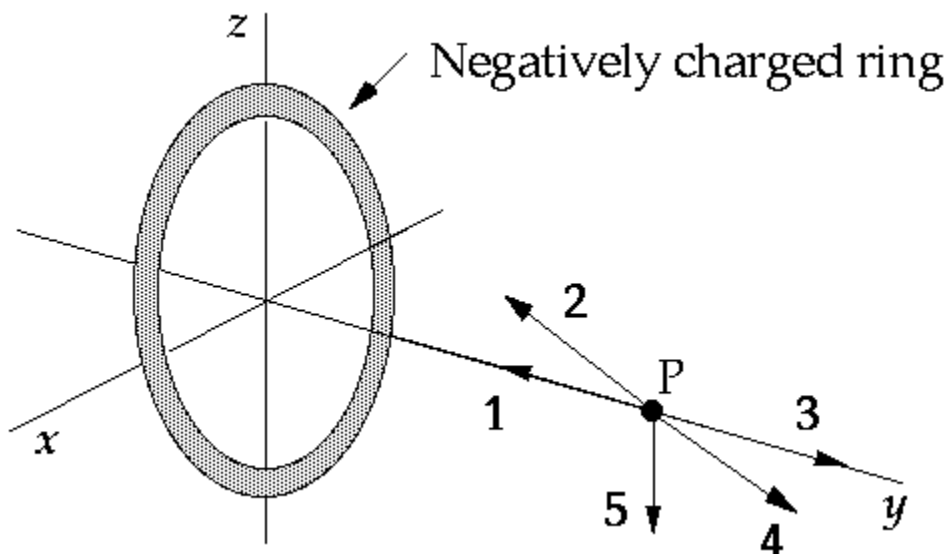

The point P is on the axis of a ring of charge, and all vectors shown lie in the yz plane. The negatively charged ring lies in the xz plane. The vector that correctly represents the direction of the electric field at this point is

- A) 1 B) 2 C) 3 D) 4 E) 5

6.

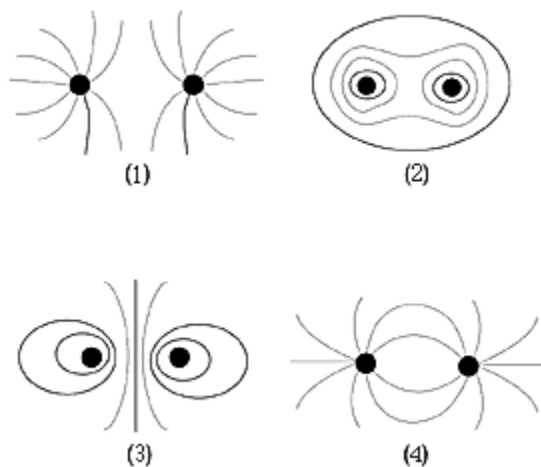

An electric dipole consists of a positive charge separated from a negative charge of the same magnitude by a small distance. Which, if any, of the diagrams best represents the electric field lines around an electric dipole?

- A) 1 B) 2 C) 3 D) 4 E) None of these is correct.

7. The power dissipated in each of two resistors is the same. The potential drop across resistor A is twice that across resistor B. If the resistance of resistor B is R , what is the resistance of A?

- A) R B) $2R$ C) $R/2$ D) $4R$ E) $R/4$

8. The drift velocity of an electron in a wire varies

- A) directly with the number of charge carriers per unit volume.
 B) directly with the cross-sectional area of the conducting wire.
 C) directly with the charge carried by it.
 D) directly with the current flowing in the conducting wire.
 E) inversely with the current flowing in the conducting wire.

9. Two pieces of copper wire have the same length, but wire A has a square cross section of width s whereas wire B has a circular cross section of diameter s . Which of the following statements is true?

- A) The resistance of both wires is the same.
- B) The resistivity of both wires is the same.
- C) Both the resistance and the resistivity of A and B are the same.
- D) The resistance of A is greater than that of B.
- E) The resistivity of A is greater than that of B.

10. A resistor carries a current I . The power dissipated in the resistor is P . What is the power dissipated if the same resistor carries current $3I$?

- A) P B) $3P$ C) $P/3$ D) $9P$ E) $P/9$

11.

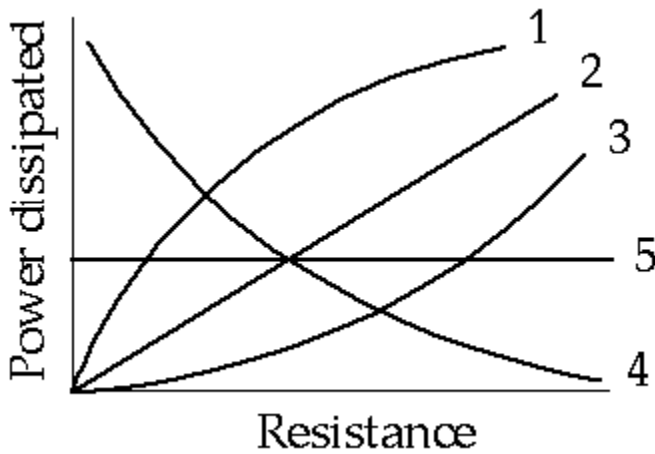

A variable resistance is connected across the terminals of a storage battery. The curve that might represent the power dissipated in the resistance as a function of the magnitude of the resistance is

- A) 1 B) 2 C) 3 D) 4 E) 5

12. Tony charges a capacitor and then discharges it through a resistor. He notices that, after two time constants, the voltage across the capacitor has decreased to _____ of its value just prior to the initiation of the discharge.

- A) $\frac{1}{2e}$ B) $\frac{1}{e}$ C) $\left(\frac{1}{e}\right)^2$ D) $2e$ E) e^2

13.

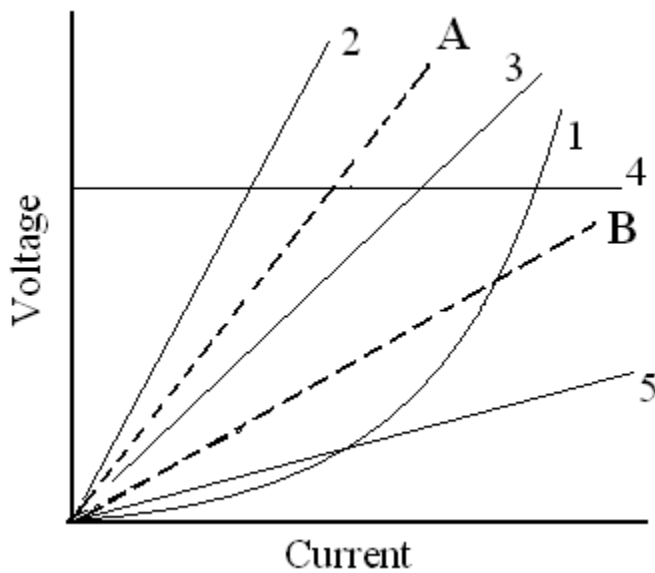

The dashed lines represent graphs of the voltage as a function of the current for two resistors A and B, respectively. The curve that might reasonably represent a graph of the data taken when the resistors are connected in series is

- A) 1 B) 2 C) 3 D) 4 E) 5

14. A battery is connected to a series combination of a switch, a resistor, and an initially uncharged capacitor. The switch is closed at $t = 0$. Which of the following statements is true?
- A) As the charge on the capacitor increases, the current increases.
 - B) As the charge on the capacitor increases, the voltage drop across the resistor increases.
 - C) As the charge on the capacitor increases, the current remains constant.
 - D) As the charge on the capacitor increases, the voltage drop across the capacitor decreases.
 - E) As the charge on the capacitor increases, the voltage drop across the resistor decreases.
15. You can change the magnetic flux through a given surface by
- A) changing the magnetic field.
 - B) changing the surface area over which the magnetic field is distributed.
 - C) changing the angle between the magnetic field and surface in question.
 - D) any combination of a through c.
 - E) none of these strategies.
16. The instantaneous induced emf in a coil of wire located in a magnetic field
- A) depends on the time rate of change of flux through the coil.
 - B) depends on the instantaneous value of flux through the coil.
 - C) is independent of the area of the coil.
 - D) is independent of the number of turns of the coil.
 - E) is determined by the resistance in series with the coil.

17. The wire is located in a region in which there is a uniform magnetic field in the y direction. You note that the induced emf in the wire is zero. From this observation, you can conclude that

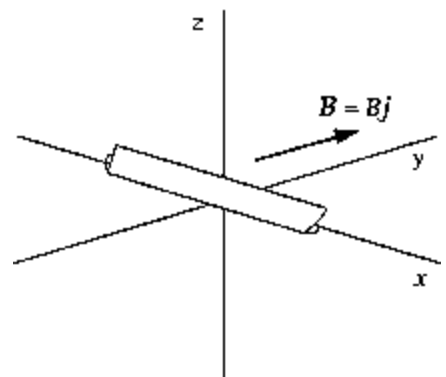

- A) it must be moving in the z direction.
- B) it must be moving in the $-z$ direction.
- C) it must be at rest or moving parallel to the magnetic field.
- D) it must be moving in such a way that its velocity vector makes an angle other than zero with \mathbf{B} .
- E) All of these are correct.

18.

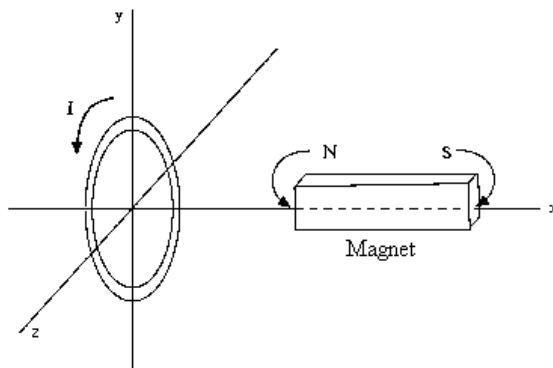

A copper ring lies in the yz plane as shown. The magnet's long axis lies along the x axis. Induced current flows through the ring as indicated. The magnet

- A) must be moving away from the ring.
- B) must be moving toward the ring.
- C) must be moving either away from or toward the ring.
- D) is not necessarily moving.
- E) must remain stationary to keep the current flowing.

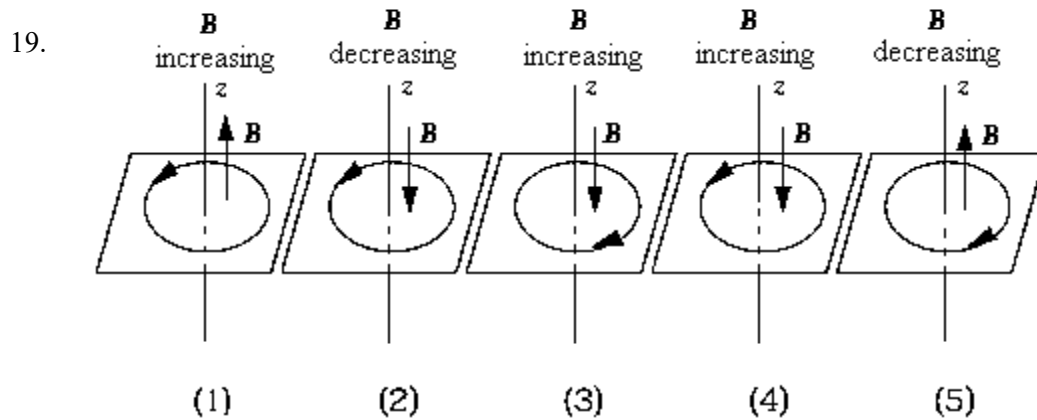

A loop rests in the xy plane. The z axis is normal to the plane and positive upward. The direction of the changing flux is indicated by the arrow on the z axis. The diagram that correctly shows the direction of the resultant induced current in the loop is

- A) 1 B) 2 C) 3 D) 4 E) 5

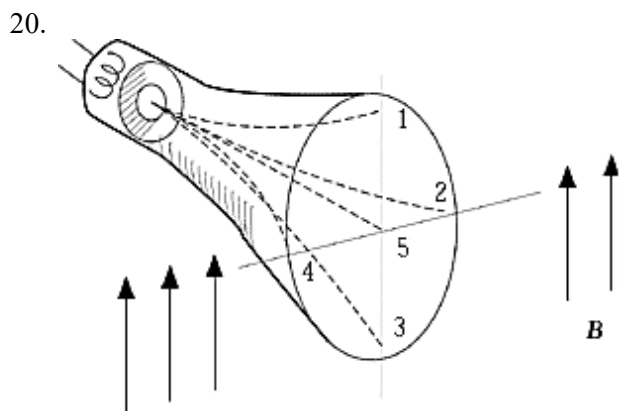

When a cathode-ray tube with its axis horizontal is placed in a magnetic field that is directed vertically upward, the electrons emitted from the cathode follow one of the dashed paths to the face of the tube. The correct path is

- A) 1 B) 2 C) 3 D) 4 E) 5

PART 2 Free Response (80 marks)

1. Three point charges are placed in the positions shown in the diagram below.

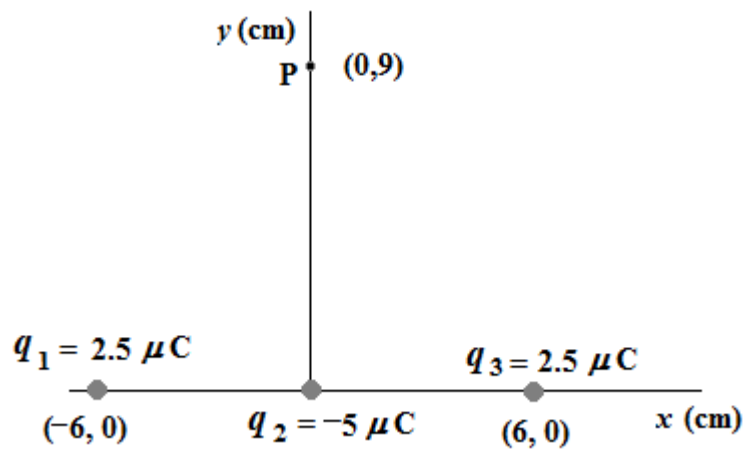

- a) Calculate the electric field at the point P due to the three fixed point charges. Express your answer in component form.

- b) If a charge $q_4 = -2.00 \mu\text{C}$ is now placed at the point P, what force (magnitude and direction) would it experience due to the three fixed point charges?

2. Three point charges are placed at three corners of a rectangle as shown below.

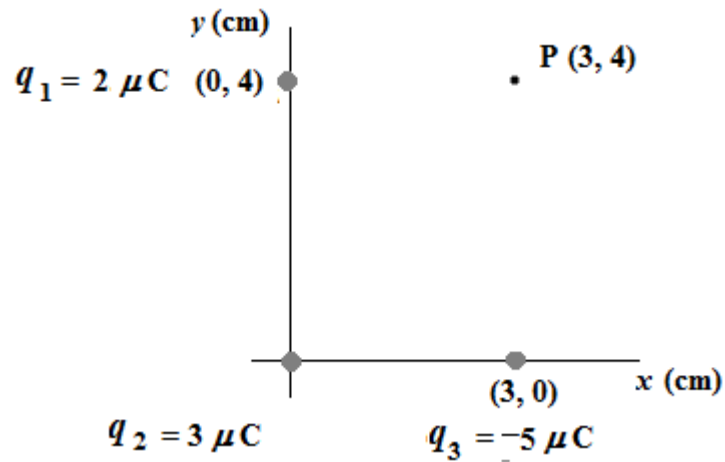

- a) Calculate the work done by an external agent in assembling this array of charges, if the charges are initially all very far away from each other.

- b) Find the electric potential V_p at point P due to the three fixed point charges.

- c) If now a fourth charge, $q_4 = +4.00 \mu\text{C}$ and mass, $m = 1.50 \times 10^{-9} \text{ kg}$ is placed at rest at P and then released, determine its speed at infinity.

- d) Why is it necessary, in part a) of this question, to state that the charges are initially "all very far away from each other"?

3. Consider the vertical deflection section of a cathode ray tube shown below.

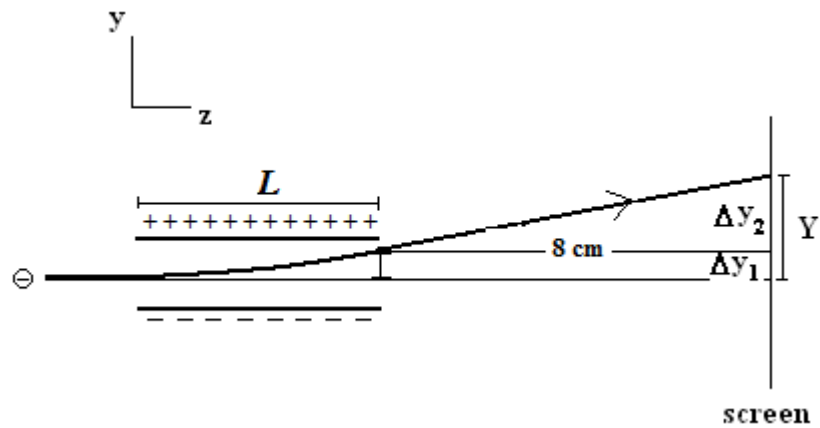

An electron with a velocity $\vec{v} = 7.00 \times 10^5 \hat{i}$ m/s enters the deflection system at right angles to a uniform electric field of magnitude 1.50×10^3 N/C.

- What is the magnitude of the acceleration experienced by the electron while between the parallel plates?
- If the y -component of the velocity of the electron as it leaves the plates is $v_y = 1.20 \times 10^6$ m/s, calculate the length L of the deflection plates.
- Find the deflection Δy_1 at the end of the deflection plates.
- The screen is 8.00 cm from the end of the deflecting plates. What is the total deflection of the electron from its original path, $\Delta y_1 + \Delta y_2$?

4.

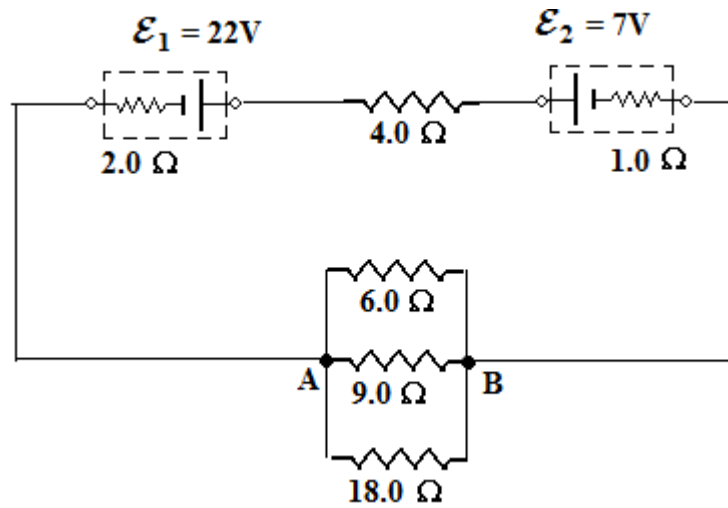

The circuit above connects two real batteries to four resistors. Battery 1 has an emf of $22.0\ \text{V}$ and an internal resistance of $2.0\ \Omega$; Battery 2 has an emf of $7.0\ \text{V}$ and an internal resistance of $1.0\ \Omega$. Solve for

- the equivalent resistance between points A and B.
- the current that flows through the $4.0\ \Omega$ resistor (Include the direction on the circuit diagram).
- the rate at which electrical energy is delivered by the Battery 1 to the rest of the circuit.
- the power absorbed by the $9.0\ \Omega$ resistor.

5. For the circuit shown,

Find:

a) the currents I_1 and I_3

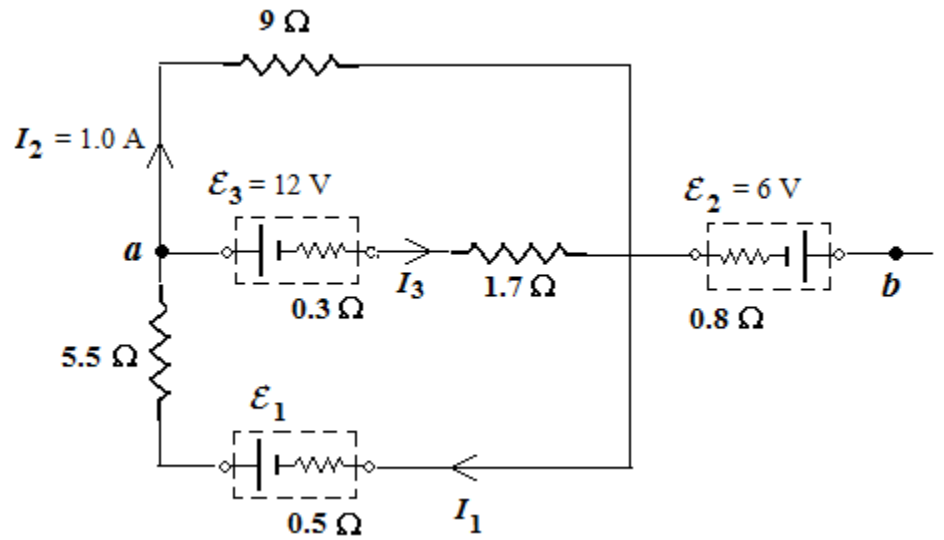

b) the emf \mathcal{E}_1

c) the potential difference from point B to point A (i.e. $V_a - V_b$)

d) Why is there no power loss in the $\mathcal{E}_2 = 6.0\text{V}$ battery?

6. In the circuit below all the capacitors were initially discharged. The switch S was closed at $t = 0$ s

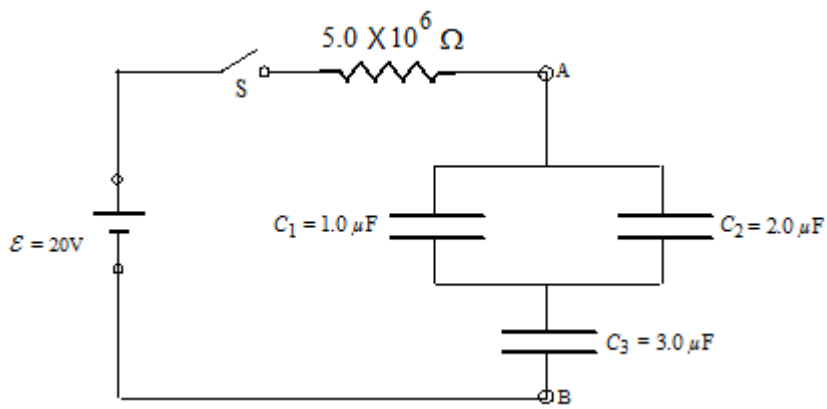

- a) What is the equivalent capacitance between points A and B?
- b) At time $t = 15$ s, what is the potential difference between points A and B?
- c) What is the charge on capacitor $C_2 = 2.0 \mu\text{F}$ at this time?
- d) What is the current through the resistor at this time?

7. (A) A particle of charge $q = -4.80 \times 10^{-19} \text{ C}$ passes undeflected through a velocity selector and then it penetrates perpendicularly into a uniform magnetic field. The particle hits a detector at a distance $d = 0.500 \text{ m}$ from where it entered the magnetic field as shown in the figure below. If the magnitude of the magnetic field in both the selector and deflector is $B = 0.400 \text{ T}$ and if they both have the same direction then:

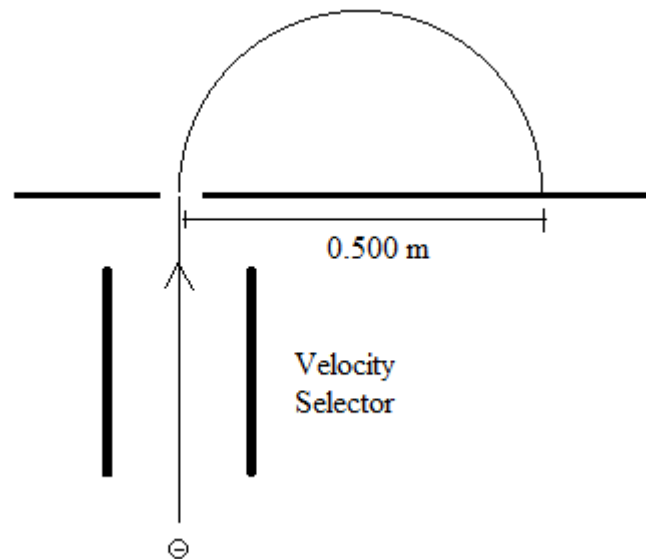

- i) Determine the direction of the magnetic field B in the deflector and selector and of the electric field E in the selector and **clearly** indicate these directions on the figure above.
- ii) Find the speed of the particle if the magnitude of the electric field in the selector is $8.00 \times 10^4 \text{ N/C}$.
- iii) Find the mass of the particle.
- iv) If the directions of B and E **in the velocity selector only** were to be reversed, explain what would happen in the velocity selector.

7. (B) Three long, straight, parallel, current carrying conductors are fixed in the positions shown in the figure below. The magnitude and sense of the current in each of the conductors are indicated in the figure.

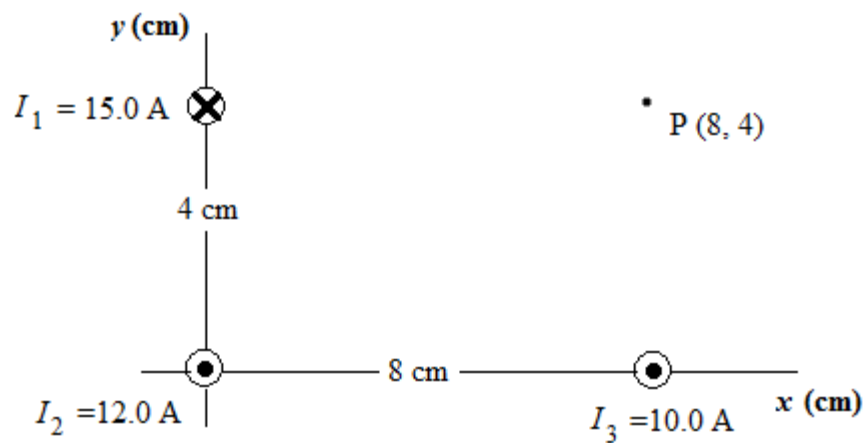

Determine the resultant magnetic field at the point **P** due to the three conductors carrying the currents I_1 , I_2 , and I_3 . Show on the figure above the direction of each of the three magnetic field vectors used in your solution. Give your answer in component form.

8. A rectangular 5.00 cm by 7.00 cm loop carrying a current $I = 3.00$ A lies in the X-Z plane as shown in the diagram. Everywhere in the region there is a uniform magnetic field with magnitude 4.00T which is parallel to the X-Y plane and makes an angle of 60° with the X-Z plane.

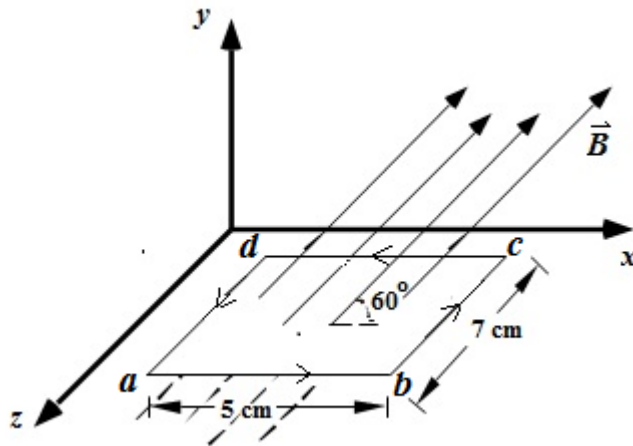

Calculate the magnitude, and show *on a separate diagram for each case* the direction, of

a) the force on the side *ab*,

b) the magnetic moment of the loop,

c) the torque on the loop.

d) On the same diagram used for part (c), indicate the sense of the rotation of the loop.

9. (A) A loop with area $3.00 \times 10^{-2} \text{ m}^2$ is in a region where there exists a uniform magnetic field with magnitude 4.00 T. Initially the field makes an angle of 30° with the plane of the loop. The loop is now rotated clockwise, in a time of 0.08 seconds, from this position to where the plane of the loop now makes an angle of 57° with the field.

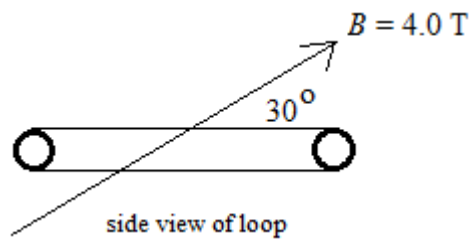

- (i) In the space provided above, draw showing the **final orientation** of the field and the loop and the direction of the **induced current** in the loop. On **this** diagram also indicate the direction of the induced magnetic field.
- (ii) Solve for the average emf induced in the loop during this rotation.

- 9.(B) A metal conducting bar with length 2.00 cm is moving on frictionless horizontal rails with constant speed “ v ” at right angles to a uniform vertical magnetic field with magnitude of $2.00 \times 10^{-3} \text{ T}$. What is the speed of the bar if the current in the 5Ω resistor is $8.00 \mu\text{A}$? Indicate the direction of the current through the resistor on the diagram given below.

