

SN2 problem set 6 answers

Part 1

Question A

Let us consider 2 wires: I_1 and I_2 . The magnetic field of I_2 is out of the page to the left and into the page to the right,

$\vec{F}_{2 \rightarrow 1} = I_1 \vec{\ell} \times \vec{B}_2$, the right hand rule tells us that the force is directed to the right

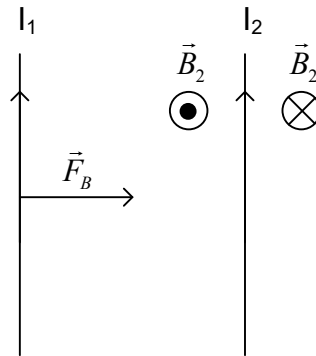

The magnetic field of I_1 is out of the page to the left and into the page to the right. If we consider the force that B_1 exerts on wire 1, $\vec{F}_{1 \rightarrow 2} = I_2 \vec{\ell} \times \vec{B}_1$, the right hand rule tells us that the force is directed to the left

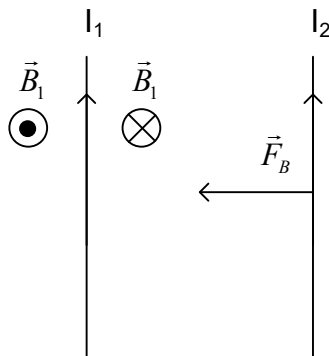

So the two wires attract each other.

Question B

First we consider the force on an electron in this conducting rod:
 $\vec{F}_B = q\vec{v} \times \vec{B}$ The right hand rule tells us that the force will be directed downward.

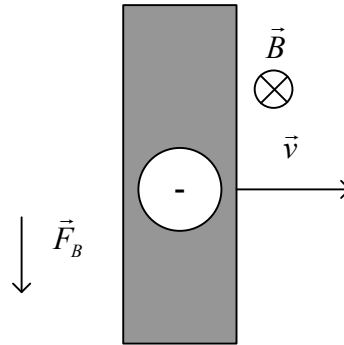

The electrons will accumulate at the bottom of the rod, creating a net negative charge and leaving a net positive charge at the top of the rod. This net charge creates an electric field as shown below.

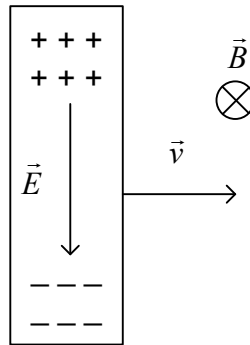

Question C

a) The magnetic field created by the current is out of the page above the wire and into the page under the wire. The magnetic field gets stronger as we get closer to the wire. As the loop falls, the magnetic field going through the loop points out of the page and the flux increases as the loop falls.

The induced field opposes the increase so the induced field is directed into the page. The right hand rule gives us the direction of the induced current: clockwise.

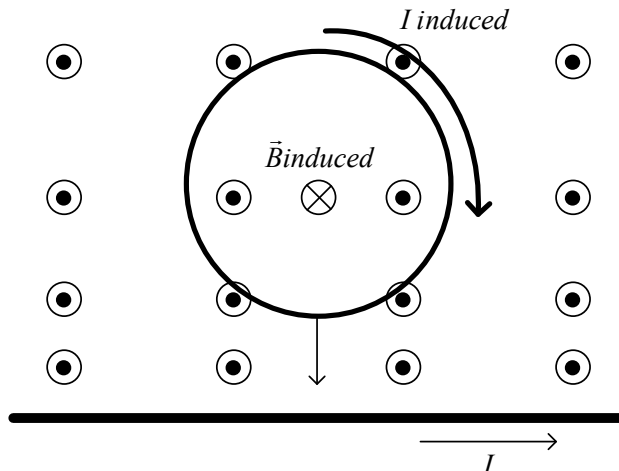

b) The answer does not change once the loop has fallen below the wire. The magnetic from wire is now into the page and decreasing
 The induced magnetic field will oppose the decrease and will be also directed into the page.

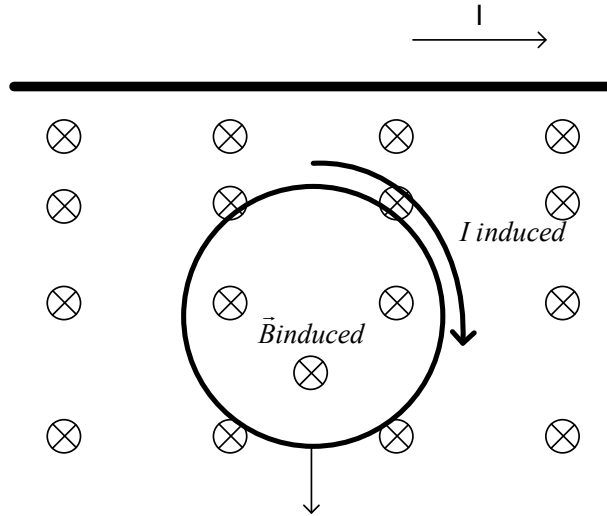

Question D

a) The magnetic field at 1 is zero which means that the magnetic field due to the wire must be pointing towards the bottom of the page

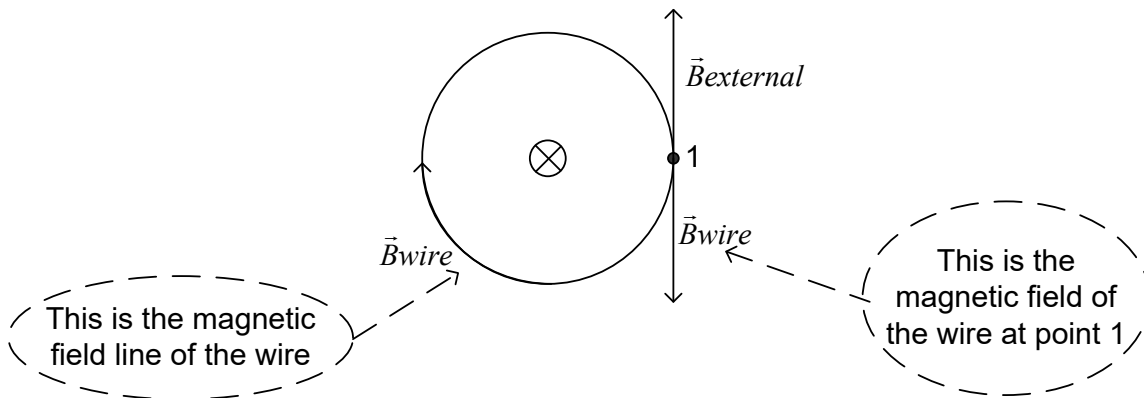

b) $B_{\text{wire}} = B_{\text{external}} = 1 \text{ T}$

therefore $\vec{B}_{\text{resultant}} = \sqrt{B_{\text{wire}}^2 + B_{\text{external}}^2} = \sqrt{2} \text{ T}$

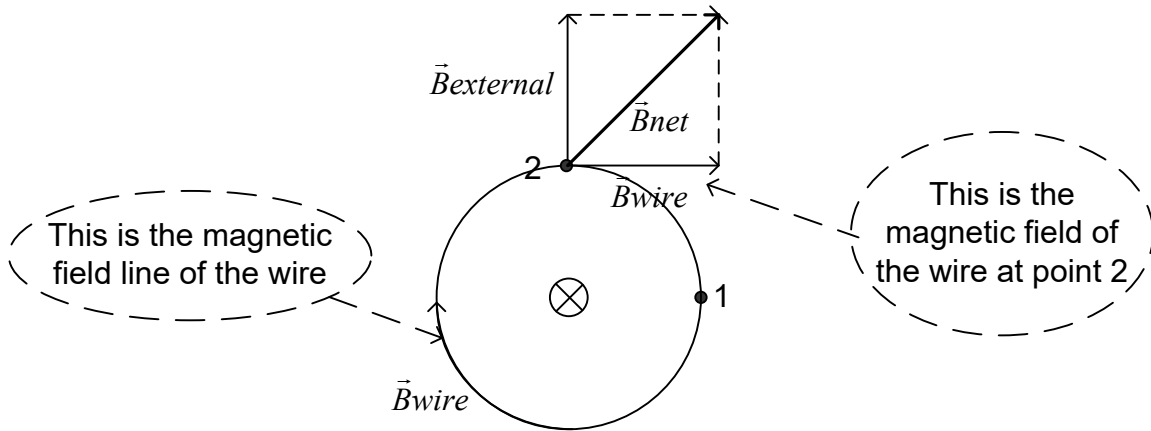

c) The formula for the magnetic field of a wire is : $B = \frac{\mu_0 I}{2\pi r}$ so if we double the distance r , we halve the magnetic field. $\vec{B}_{\text{wire}} + \vec{B}_{\text{external}} = \frac{1}{2} \text{ T}$

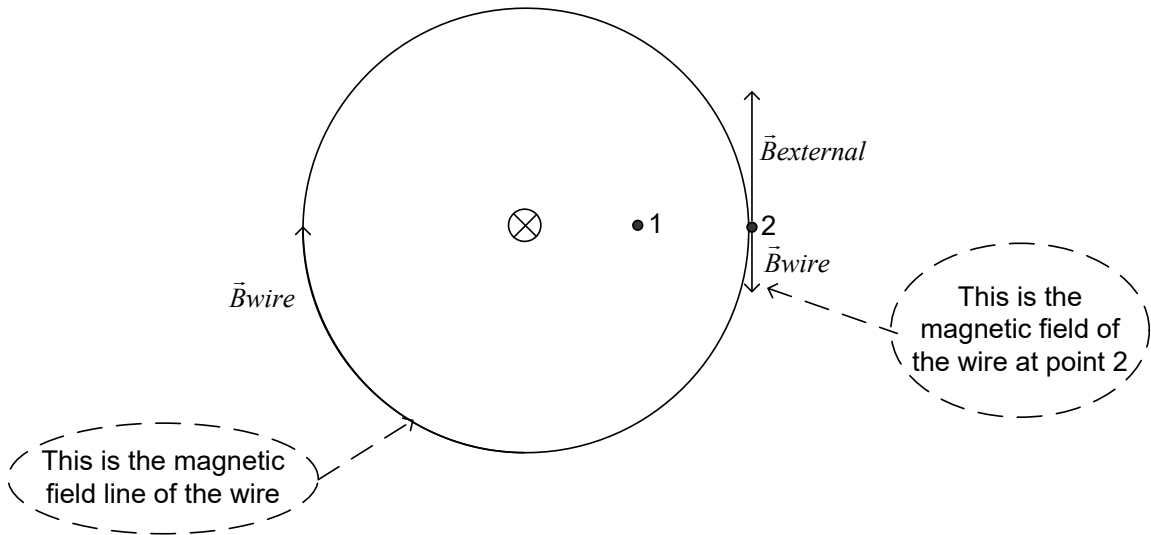

Question E

a) by Newton's third law

Question F

By the right hand rule illustrated below (current comes out of the page) the magnetic field north of the wire points west

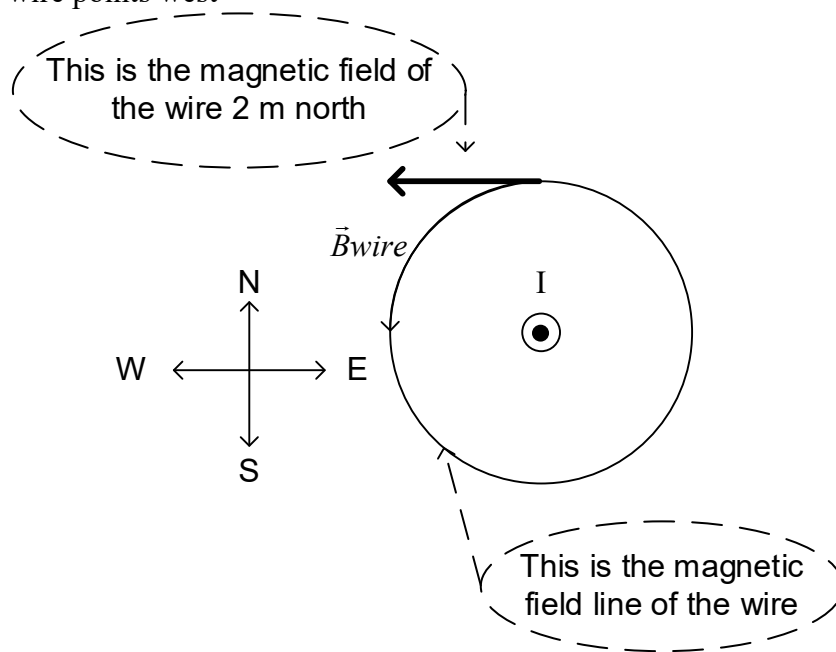
**Question G**

a) The external magnetic field is upward and increasing. The induced magnetic field will oppose the change in this increase. The induced field will therefore point into the page. By the right hand rule, the current will be clockwise

b) $\vec{\tau} = \vec{\mu} \times \vec{B}$, $|\tau| = \mu B \sin \theta$. The angle between μ and B is 180° so there is no torque

c) If the magnetic field B_0 begins to decrease, the induced magnetic field will oppose the change and be out of the page. The induced current would now be anti-clockwise.

Question H

ANS: c)

Question I

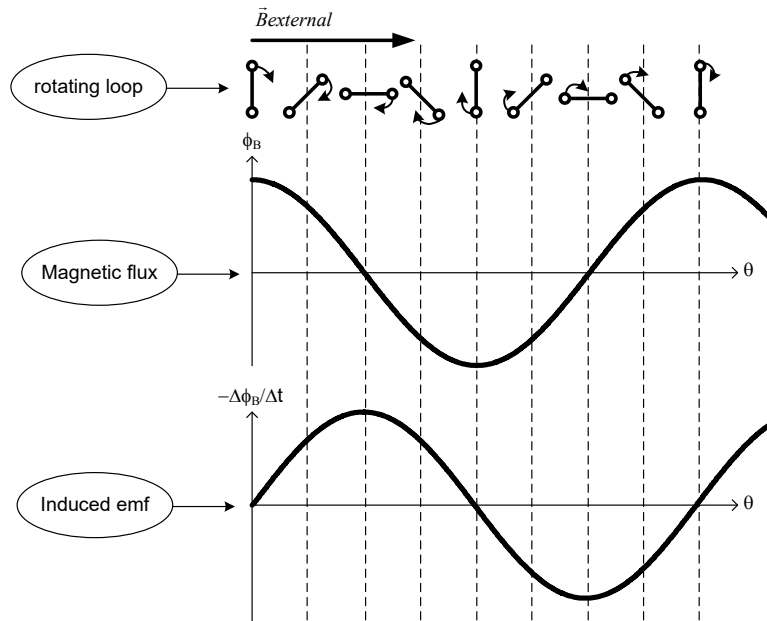

Part B

Question 1

At point P (location of third wire, the magnetic field due to I_1 and I_2 is as shown.

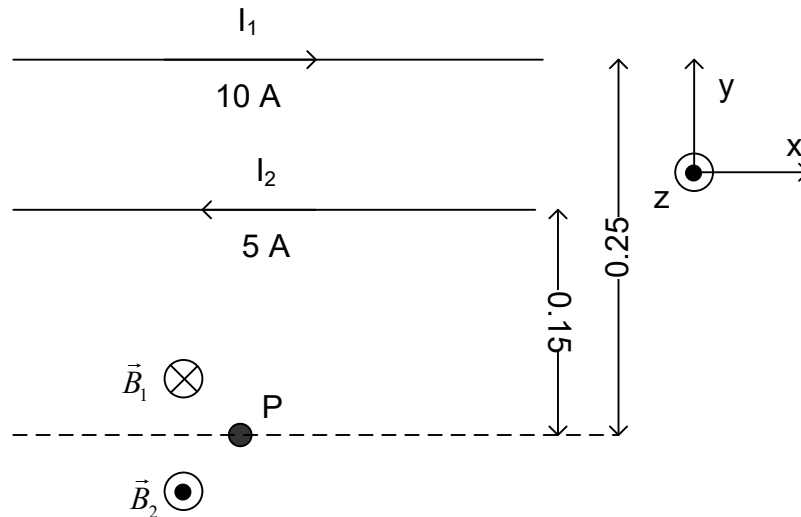

$$a) \vec{B}_p = \vec{B}_1 + \vec{B}_2$$

$$\vec{B}_p = -B_1 \hat{k} + B_2 \hat{k}$$

$$B_{\text{long wire}} = \frac{\mu_0 I}{2\pi r}$$

$$\vec{B}_p = -\frac{2 \times 10^{-7} \times 10}{0.25} \hat{k} + \frac{2 \times 10^{-7} \times 5}{0.15} \hat{k}$$

$$\vec{B}_p = -1.33 \times 10^{-6} \hat{k} \text{ T}$$

The resultant magnetic field at the position of the wire is $-1.33 \times 10^{-6} \text{ T}$

$$\text{b) } \vec{F}_3 = I_3 \vec{\ell} \times \vec{B}_p \therefore \vec{B}_p = 0 \text{ [sin}\theta=1\text{]}$$

To cancel out the field due to I_1, I_2 needs to travel towards the left, as in (a).

$$-B_1 \hat{k} + B_2 \hat{k} = 0$$

$$B_1 = B_2$$

$$\frac{\mu_0 I_1}{2\pi r_1} = \frac{\mu_0 I_2}{2\pi r_2}$$

$$I_2 = I_1 \frac{r_2}{r_1}$$

$$I_2 = 10 \times \frac{0.15}{0.25} = 6.00 \text{ A}$$

If the current in I_2 was 6.00 A, the wire would experience no net force due to the other two conductors.

Question 2

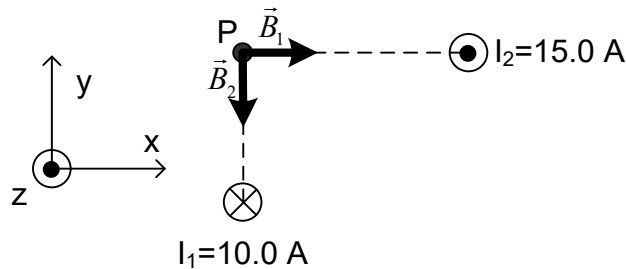

$$\vec{B}_p = \vec{B}_1 + \vec{B}_2$$

$$\vec{B}_p = B_1 \hat{i} - B_2 \hat{j}$$

$$\vec{B}_p = \frac{\mu_0 I_1}{2\pi r_1} \hat{i} - \frac{\mu_0 I_2}{2\pi r_2} \hat{j}$$

$$\vec{B}_p = 2 \times 10^{-7} \times \frac{10}{0.06} \hat{i} - 2 \times 10^{-7} \times \frac{15}{0.08} \hat{j}$$

$$\vec{B}_p = (3.33 \times 10^{-5} \hat{i} - 3.75 \times 10^{-5} \hat{j}) \text{ T}$$

$$\vec{F} = q\vec{v} \times \vec{B}$$

$$\vec{F} = (-1.6 \times 10^{-19}) \times \begin{vmatrix} \hat{i} & \hat{j} & \hat{k} \\ 0 & 0 & -3 \times 10^6 \\ 3.33 \times 10^{-5} & -3.75 \times 10^{-5} & 0 \end{vmatrix}$$

$$\vec{F} = (1.80 \times 10^{-17} \hat{i} + 1.60 \times 10^{-17} \hat{j}) \text{ N}$$

The force that the electron experiences is $\vec{F} = (1.80 \times 10^{-17} \hat{i} + 1.60 \times 10^{-17} \hat{j}) \text{ N}$.

Question 3

a)

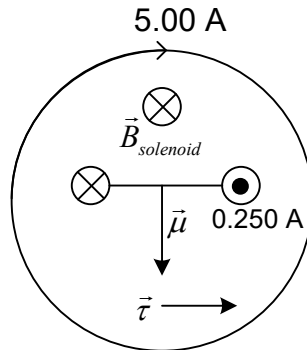

$$b) \quad B = \mu n i = 4\pi \times 10^{-7} \times \frac{40}{10^{-2}} \times 5$$

The magnetic field inside a solenoid is: $B = -0.025 \hat{k} \text{ T}$

$$c) \quad \vec{\tau} = \vec{\mu} \times \vec{B} = |\vec{\mu}| |\vec{B}| \sin \theta \hat{i}$$

$$\vec{\tau} = NIA(0.025) \sin 90 \hat{i}$$

$$\vec{\tau} = 1 \times 0.25 \times (3 \times 10^{-2})^2 \times 0.025 \times \sin 90 \hat{i}$$

The torque on the loop is $\vec{\tau} = 5.63 \times 10^{-6} \hat{i} \text{ N} \times \text{m}$

Question 4

$$\phi_{\text{initial}} = \vec{B} \times \vec{A} = BA \cos \theta$$

$$\phi_{\text{initial}} = 6 \times \pi \times 0.1^2$$

$$\phi_{\text{initial}} = 0.188 \text{ Tm}^2$$

$$\phi_{\text{final}} = 0 \text{ Tm}^2$$

$$\varepsilon = \frac{\Delta \phi}{\Delta t} = \frac{\phi_{\text{final}} - \phi_{\text{initial}}}{\Delta t} = \frac{0.188 \text{ Tm}^2}{0.1 \text{ s}}$$

The induced emf is $\varepsilon = 1.88 \text{ V}$ and the direction of the current is indicated on the picture

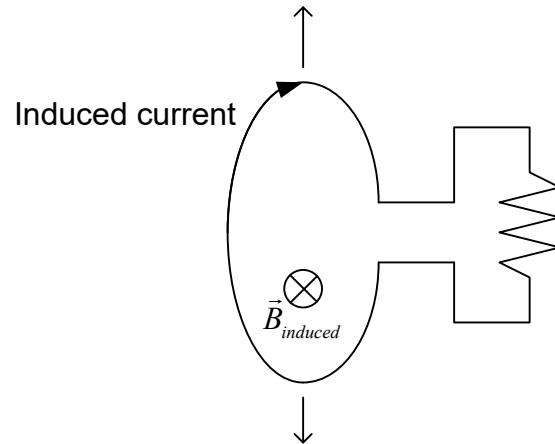

Question 5

a)

$$B_{\text{solenoid}} = \mu_0 n I$$

$$(\text{Flux through solenoid}) = (B_{\text{solenoid}})(A_{\text{solenoid}})$$

$$\Delta \phi_{\text{solenoid}} = \phi_{\text{final}} - \phi_{\text{initial}}$$

$$\Delta \phi_{\text{solenoid}} = A \mu_0 n (I_f - I_i)$$

$$\Delta \phi_{\text{solenoid}} = \pi (0.06)^2 (4\pi \times 10^{-7}) (5 \times 10^4) (20 - 50)$$

$$\Delta \phi = -0.0213 \text{ Wb}$$

$\Delta \phi_{\text{pick up coil}} = \Delta \phi_{\text{solenoid}}$ (There are essentially no field lines due to the solenoid outside of the solenoid, assuming it is ideal)

$$|\varepsilon_{\text{av coil}}| = \left| N \frac{\Delta \phi}{\Delta t} \right| = 200 \frac{0.0213}{0.3} = 14.2 \text{ V}$$

The average induced emf in the pick-up coil is 14.2 V

$$\text{b) } I = \frac{\varepsilon}{R} = \frac{14.2}{57} = 0.249 \text{ A}$$

The magnitude of the current is 0.249 A and the direction of the current is indicated in the picture.

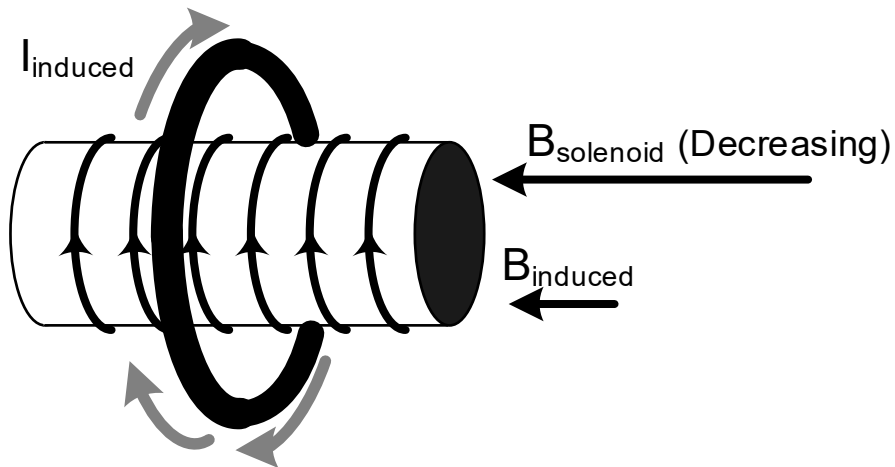

Question 6

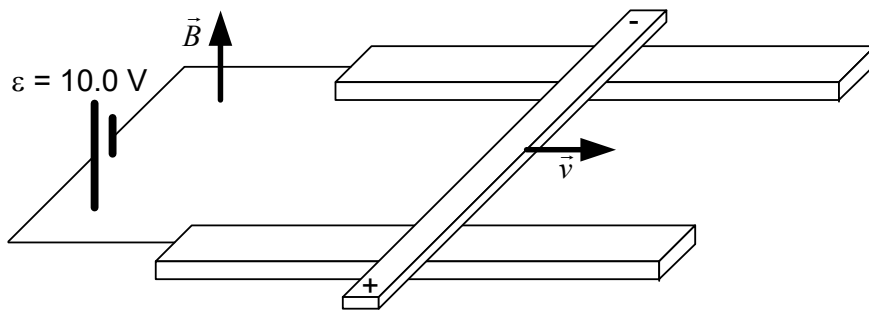

a) The direction of the induced emf is shown on the picture.

$$\epsilon = B\ell v$$

$$\epsilon = 2 \times 3 \times 10^{-2} \times 30 = 1.80 \text{ V}$$

The induced emf in the moving bar is 1.80 V

b) Let's draw a circuit equivalent to the picture of the situation:

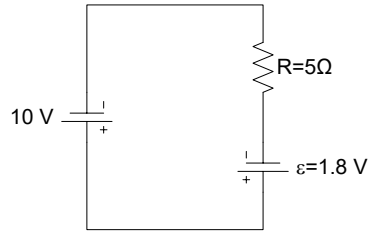

Let's apply the loop rule $10 - 1.8 - 5 \times I = 0$

$$10 - 1.8 - 5 \times I = 0 \rightarrow I = \frac{8.2}{5} \rightarrow I = 1.64 \text{ A}$$

The current in the rails is 1.64 A counter-clockwise

c) $F_B = I \ell B \sin \theta = 1.64 \times 3 \times 10^{-2} \times 2 \times \sin 90 = 9.84 \times 10^{-2} \text{ N}$

by the right hand rule \vec{F}_B points to the right

If the bar moves with a constant speed (zero acceleration), the net force applied to it must

be zero: $\vec{F}_{net} = \vec{F}_B + \vec{F}_{applied} = 0$

So the applied force must be $9.84 \times 10^{-2} \text{ N}$ to the left

Question 7

a) $|\tau| = \mu B \sin \theta$ where B is the magnetic field incident on the loop due to the solenoid so,

$$B_{sol} = \frac{|\tau|}{\mu \sin \theta} = \frac{|\tau|}{(N_{ring} I_{ring} A) \sin \theta} = \frac{5 \times 10^{-9}}{1 \cdot 20 \text{ mA} \cdot \pi \cdot 0.05^2 \sin 140^\circ} = 49.5 \mu T$$

b)

$$B = \mu_0 \left(\frac{N}{L} \right) I$$

$$\Rightarrow L = \mu_0 \left(\frac{N}{B} \right) I = (4\pi \times 10^{-7}) \left(\frac{400}{49.5 \mu T} \right) 5 \text{ mA} \approx 0.05 \text{ m}$$

$$L = 0.05 \text{ m}$$

c) μ tends to align itself with the magnetic field that is causing the torque, and since we know there is a torque acting on it, then μ (and so the loop) will rotate through an angle $50^\circ + 90^\circ = 140^\circ$ to align itself with B . Since $\Phi = BA\cos\theta$, the angle θ is changing (rotating) thus $\Delta\Phi \neq 0$ meaning $\varepsilon_{ind} \neq 0$. Since the other quantities B and A remain unchanged the only change is in θ and so the induced *emf* is

$$\varepsilon = -N \frac{\Delta\Phi}{\Delta t} = -N \frac{\Delta(BA\cos\theta)}{\Delta t} = -N BA \frac{\Delta\cos\theta}{\Delta t} = -NBA \frac{(\cos\theta_f - \cos\theta_i)}{\Delta t}$$

$$\varepsilon = -(1)(4.95\mu T)(\pi \cdot 0.05^2) \frac{(\cos 0^\circ - \cos 140^\circ)}{\Delta t} = -68.6 \times 10^{-9} \frac{V}{s}$$

$$R_{loop} = \frac{\rho L}{A} = \frac{(1.68 \times 10^{-8} \Omega m)(2\pi \cdot 0.05 m)}{1 \times 10^{-6} m^2} = 0.52 \times 10^{-2} \Omega$$

$$I_{ind} = \frac{\varepsilon}{R_{loop}} = \frac{68.6 \times 10^{-9} V/s}{0.52 \times 10^{-2} \Omega} = \frac{13.2 \times 10^{-6}}{\Delta t} A$$

Question 8

a) initial area $\pi r^2 = \frac{\pi}{16} m^2 \approx 0.196 m^2$

final area $r^2 = \frac{\pi^2}{36} m^2 \approx 0.274 m^2$

initial field $B = 20.0 \times 10^{-6} T$

final field $B = 100.0 \times 10^{-6} T$

$$\varepsilon = -N \frac{\Delta\Phi}{\Delta t} = \frac{(BA\cos\theta)_f - (BA\cos\theta)_i}{\Delta t}$$

$$\varepsilon = -1 \frac{100 \times 10^{-6} \times 0.274 \times \cos 0^\circ - 20 \times 10^{-6} \times 0.196 \times \cos 20^\circ}{0.01}$$

$$\varepsilon = 2.37 \times 10^{-3} V$$

The induced current inside the wire is $I = \frac{V}{R} = \frac{2.37 \times 10^{-3}}{10} = 2.37 \times 10^{-4} A$

b) The induced current is initially in the same direction as the 2.00A current in the loop. The induced magnetic field opposes the external magnetic field, and is at 90° to the loop.